

Product Preview
PowerPC™ Microcontroller

Features

- PowerPC™ Core with Floating-Point Unit
- 26 Kbytes Fast RAM and 6 Kbytes TPU Microcode RAM
- 448 Kbytes Flash EEPROM with 5V Programming
- 5V I/O System
- Serial System: Queued Serial Multi-Channel Module (QSMCM), Dual CAN 2.0B Controller Modules (TouCAN™)
- 50-Channel Timer System: Dual Time Processor Units (TPU3), Modular I/O System (MIOS1)
- 32 Analog Inputs: Dual Queued Analog-to-Digital Converters (QADC64)
- Submicron HCMOS (CDR1) Technology
- 272-Pin Plastic Ball Grid Array (PBGA) Packaging
- 40-MHz operation, -40° C to 125° C with Dual Supply (3.3V, 5V)

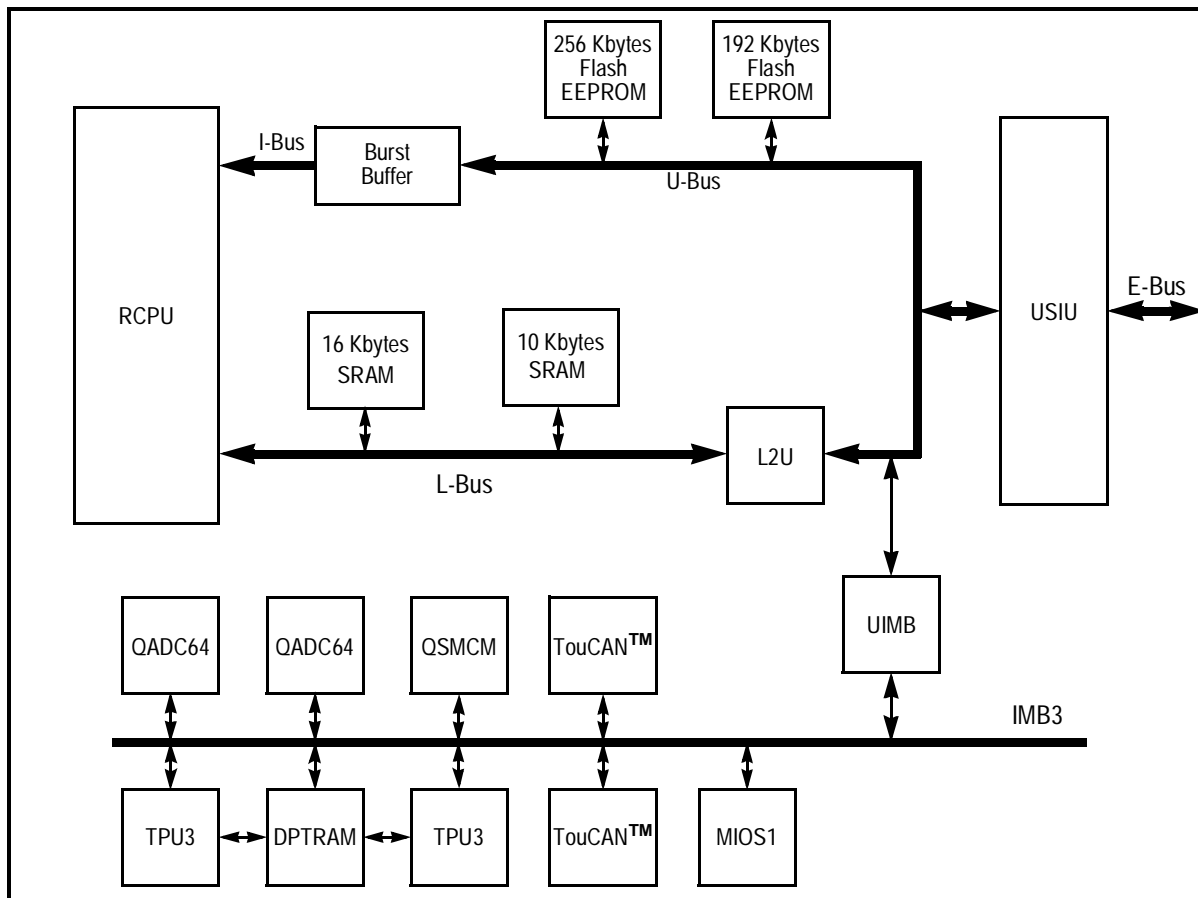

This document contains information on a new product. Specifications and information herein are subject to change without notice.



RISC MCU Central Processing Unit (RCPU)

- 32-Bit PowerPC™ Architecture (compliant with PowerPC™ Architecture Book 1)
- Core performance measured at 52.7K Dhrystones (v2.1) @ 40 MHz
- Fully static, low power operation
- Integrated double-precision floating-point unit
- Precise exception model
- Extensive system development support
 - On-chip watchpoints and breakpoints
 - Program flow tracking
 - BDM on-chip emulation development interface

Four-Bank Memory Controller

- Works with SRAM, EPROM, flash EEPROM, and other peripherals
- Byte write enables
- 32-bit address decodes with bit masks

U-Bus System Interface Unit (USIU)

- Clock synthesizer
- Power management
- Reset controller
- PowerPC™ decremter and time base
- Real-time clock register
- Periodic interrupt timer
- Hardware bus monitor and software watchdog timer
- Interrupt controller that supports up to eight external and eight internal interrupts
- IEEE 1149.1 JTAG test access port
- External bus interface
 - 24 address pins, 32 data pins
 - Supports multiple master designs
 - Four-beat transfer bursts, two-clock minimum bus transactions
 - Supports 5V inputs, provides 3.3V outputs

Flexible Memory Protection Unit

- Four instruction regions and four data regions
- 4-Kbyte to 16-Mbyte region size support
- Default attributes available in one global entry
- Attribute support for speculative accesses

448-Kbyte Flash EEPROM Memory

- One 256-Kbyte and one 192-Kbyte module
- Page read mode
- Block (32-Kbyte) erasable
- External 4.75V to 5.25V program and erase power supply

26-Kbytes of Static RAM

- One 16-Kbyte and one 10-Kbyte module
- Fast (one-clock) access
- Keep-alive power
- Soft defect detection (SDD)

General-Purpose I/O Support

- Address (24) and data (32) pins can be used for general-purpose I/O in single-chip mode
- 9 general-purpose I/O pins in MIOS1 unit
- Many peripheral pins can be used for general-purpose I/O when not used for primary function
- 5V tolerant inputs/outputs

Two Time Processor Units (TPU3)

- Each TPU3 module provides these features:
 - A dedicated micro-engine operates independently of the RCPU
 - 16 independent programmable channels and pins
 - Each channel has an event register consisting of a 16-bit capture register, a 16-bit compare register and a 16-bit comparator
 - Nine pre-programmed timer functions are available
 - Any channel can perform any time function
 - Each timer function can be assigned to more than one channel
 - Two timer count registers with programmable prescalers
 - Each channel can be synchronized to one or both counters
 - Selectable channel priority levels
 - 5V tolerant inputs/outputs
- 6-Kbyte dual port TPU RAM (DPTRAM) is shared by the two TPU3 modules for TPU microcode

18-Channel Modular I/O System (MIOS1)

- Ten double action submodules (DASM)
- Eight dedicated PWM sub-modules (PWMSM)
- Two 16-bit modulus counter submodules (MCSM)
- Two parallel port I/O submodules (PIOSM)
- 5V tolerant inputs/outputs

Two Queued Analog-to-Digital Converter 2 Modules (QADC64)

Each QADC provides:

- Up to 16 analog input channels, using internal multiplexing
- Up to 41 total input channels, using internal and external multiplexing
- 10-bit A/D converter with internal sample/hold
- Typical conversion time of 10 μ sec (100,000 samples per second)
- Two conversion command queues of variable length
- Automated queue modes initiated by:
 - External edge trigger/level gate
 - Software command
- 64 result registers
- Output data that is right- or left-justified, signed or unsigned
- 5V reference and range

Two CAN 2.0B Controller Modules (TouCAN™)

Each TouCAN™ provides these features:

- Full implementation of CAN protocol specification, version 2.0A and 2.0B
- Each module has 16 receive/transmit message buffers of 0 to 8 bytes data length
- Global mask register for message buffers 0 to 13
- Independent mask registers for message buffers 14 and 15
- Programmable transmit-first scheme: lowest ID or lowest buffer number
- 16-bit free-running timer for message time-stamping
- Low power sleep mode with programmable wake-up on bus activity
- Programmable I/O modes
- Maskable interrupts
- Independent of the transmission medium (external transceiver is assumed)
- Open network architecture
- Multimaster concept
- High immunity to EMI
- Short latency time for high-priority messages
- Low power sleep mode with programmable wakeup on bus activity

Queued Serial Multi-Channel Module (QSMCM)

- Queued serial peripheral interface (QSPI)
 - Provides full-duplex communication port for peripheral expansion or interprocessor communication
 - Up to 32 preprogrammed transfers, reducing overhead
 - 160-byte queue buffer
 - Programmable transfer length: from 8 to 16 bits, inclusive
 - Synchronous interface with baud rate of up to system clock divided by 4
 - Four programmable peripheral-select pins support up to 16 devices
 - Wrap-around mode allows continuous sampling for efficient interfacing to serial peripherals (e.g. – serial A/D converters, I/O latches, etc.)
- Two serial communications interfaces (SCI). Each SCI offers these features:
 - UART mode provides NRZ format and half-or full-duplex interface
 - 16 register receive buffer and 16 register transmit buffer (SCI1 only)
 - Advanced error detection and optional parity generation and detection
 - Word length programmable as 8 or 9 bits
 - Separate transmitter and receiver enable bits and double buffering of data
 - Wakeup functions allow the CPU to run uninterrupted until either a true idle line is detected or a new address byte is received
 - External source clock for baud generation
 - Multiplexing of transmit data pins with discrete outputs and receive data pins with discrete inputs, allowing realization of a low-speed serial protocol

Motorola reserves the right to make changes without further notice to any products herein. Motorola makes no warranty, representation or guarantee regarding the suitability of its products for any particular purpose, nor does Motorola assume any liability arising out of the application or use of any product or circuit, and specifically disclaims any and all liability, including without limitation consequential or incidental damages. "Typical" parameters which may be provided in Motorola data sheets and/or specifications can and do vary in different applications. All operating parameters, including "Typicals" must be validated for each customer application by customer's technical experts. Motorola does not convey any license under its patent rights nor the rights of others. Motorola products are not designed, intended, or authorized for use as components in systems intended for surgical implant into the body, or other applications intended to support or sustain life, or for any other application in which the failure of the Motorola product could create a situation where personal injury or death may occur. Should Buyer purchase or use Motorola products for any such unintended or unauthorized application, Buyer shall indemnify and hold Motorola and its officers, employees, subsidiaries, affiliates, and distributors harmless against all claims, costs, damages, and expenses, and reasonable attorney fees arising out of, directly or indirectly, any claim of personal injury or death associated with such unintended or unauthorized use, even if such claim alleges that Motorola was negligent regarding the design or manufacture of the part.

MCUinit, MCUasm, MCUdebug, and RTEK are trademarks of Motorola, Inc. MOTOROLA and ! are registered trademarks of Motorola, Inc. Motorola, Inc. is an Equal Opportunity/Affirmative Action Employer.

How to reach us:

USA/EUROPE/Locations Not Listed: Motorola Literature Distribution;
P.O. Box 20912; Phoenix, Arizona 85036. 1-800-441-2447 or 602/303-5454

MFAX: RMFAX0@email.sps.mot.com - TOUCHTONE (602) 244-6609

INTERNET: <http://Design-NET.com>

JAPAN: Nippon Motorola Ltd.; Tatsumi-SPD-JLDC,
6F Seibu-Butsuryu-Center, 3-14-2 Tatsumi Koto-Ku, Tokyo 135, Japan. 03-3521-8315

ASIA PACIFIC: Motorola Semiconductors H.K. Ltd.; 8B Tai Ping Industrial Park,
51 Ting Kok Road, Tai Po, N.T., Hong Kong. 852-26629298



MOTOROLA