

XH CONNECTOR

Disconnectable Crimp style connectors

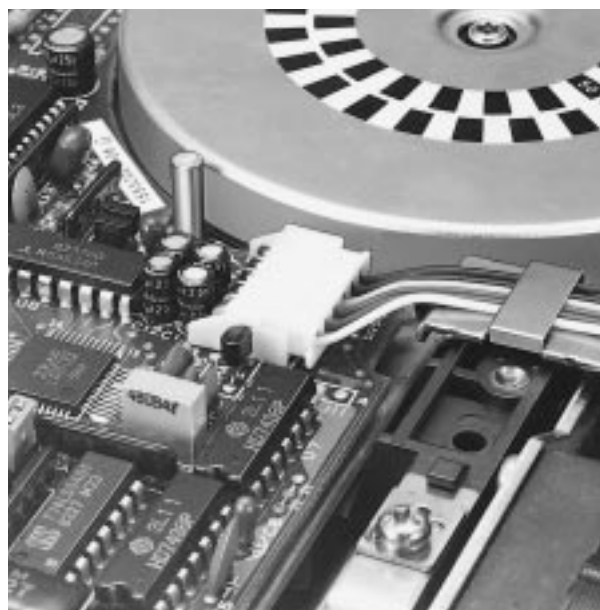

The XH connector was developed based on the high reliability and versatility of our NH series connectors. The connector is very small with a mounting height of 9.8mm (.386"). Yet it meets the needs for high-density mounting and miniaturization of electronic equipment, including VCRs, radio-cassette players, and car stereo systems.

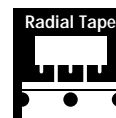
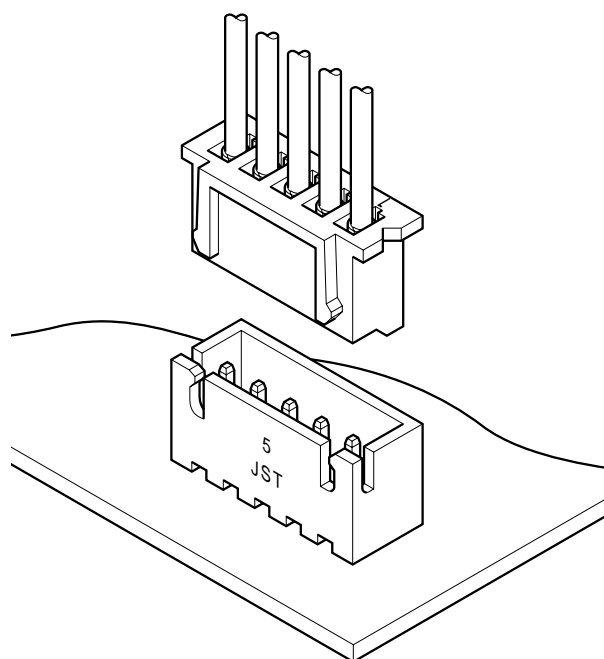

Features

• Original folded beam contact

The protected, folded beam contact in this connector provides high contact pressure with an over-stress stop feature. This ensures dependable continuity when used with low voltage, low current carrying circuits (dry circuits). The wire crimp section is mechanically decoupled from the post insertion section which, in turn, prevents the mating area from being adversely affected by crimping.

• Box-shaped shrouded header

The four-sided, box-shaped shroud prevents the receptacle from being misinserted or pried during insertion and removal. The shroud also prevents foreign matter from reaching the posts and resists contact deformation due to handling and shipping. Furthermore, a serrated, oversized square post is pressure-fit into each square hole to completely protect the post against heat and to prevent flux from entering during dip soldering.

• Header with a boss

This header has a boss (projection) on the bottom of the housing to prevent improper insertion in printed circuit boards.

• Whisker prevention

The contact is treated with a reflow process and the square post is copper-undercoated and tin/lead-plated to prevent whiskers from being generated.

• Interchangeability

This header is interchangeable with those of 2.5mm (.098") pitch insulation displacement NR, NRD and BR connectors and board-to-board JQ connectors.

• Conforming to the HA terminal

The 4-circuit XH connector conforms to the HA terminal specified in JEM 1427 (Japanese Electric Machine Industry Association Standards).

Specifications

- Current rating: 3.0A AC, DC
 - Voltage rating: 250V AC, DC
 - Temperature range: -25°C to +85°C
(including temperature rise in applying electrical current)
 - Contact resistance: Initial value/10m Ω max.
After environmental testing/20m Ω max.
 - Insulation resistance: 1,000MΩ min.
 - Withstanding voltage: 1,000V AC/minute
 - Applicable wire: AWG #30 to #22
 - Applicable PC board thickness: 1.6mm(.063")
- * Contact JST for details.

Standards

Recognized file No. E60389

Certified file No. LR20812

File No. R75085 (conforms to DIN/VDE 0627)

XH CONNECTOR

Contact

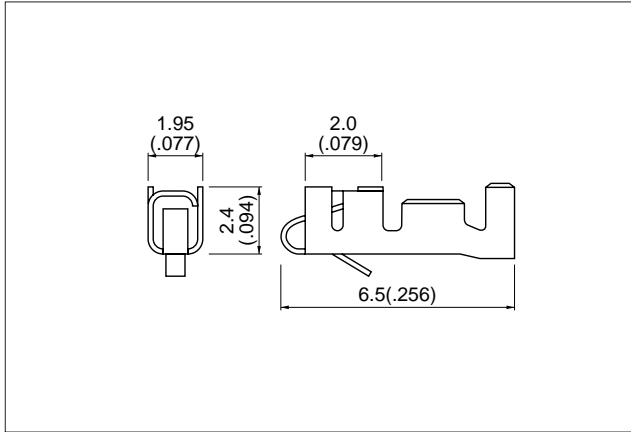

Model No.	Applicable Wire			Qty / reel
	mm ²	AWG#	Insulation O.D mm(in.)	
SXH-001T-P0.6	0.08 to 0.33	28 to 22	1.2 to 1.9(.047 to .075)	8,000
SXH-002T-P0.6	0.05 to 0.13	30 to 26	0.9 to 1.3(.035 to .051)	

Material and Finish
Phosphor bronze, tin-plated

- Note:
 1. Contact JST if you require gold-plated contacts or contacts made of brass.
 2. Also Contact JST also if you require shielded wires, coaxial cables, thin wires or other special wires.

Housing

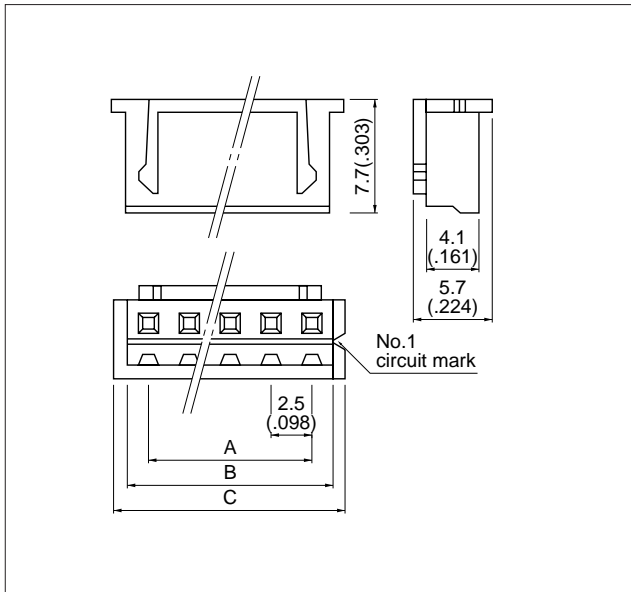

Circuits	Model No.	Dimensions mm(in.)			Qty / bag
		A	B	C	
1	XHP- 1	—	3.2(.126)	4.8(.189)	1,000
2	XHP- 2	2.5(.098)	5.7(.224)	7.3(.287)	1,000
3	XHP- 3	5.0(.197)	8.2(.323)	9.8(.386)	1,000
4	XHP- 4	7.5(.295)	10.7(.421)	12.3(.484)	1,000
5	XHP- 5	10.0(.394)	13.2(.520)	14.8(.583)	1,000
6	XHP- 6	12.5(.492)	15.7(.618)	17.3(.681)	1,000
7	XHP- 7	15.0(.591)	18.2(.717)	19.8(.780)	1,000
8	XHP- 8	17.5(.689)	20.7(.815)	22.3(.878)	1,000
9	XHP- 9	20.0(.787)	23.2(.913)	24.8(.976)	1,000
10	XHP-10	22.5(.886)	25.7(1.012)	27.3(1.075)	1,000
11	XHP-11	25.0(.984)	28.2(1.110)	29.8(1.173)	1,000
12	XHP-12	27.5(1.083)	30.7(1.209)	32.3(1.272)	1,000
13	XHP-13	30.0(1.181)	33.2(1.307)	34.8(1.370)	1,000
14	XHP-14	32.5(1.280)	35.7(1.406)	37.3(1.469)	1,000
15	XHP-15	35.0(1.378)	38.2(1.504)	39.8(1.567)	1,000
16	XHP-16	37.5(1.476)	40.7(1.602)	42.3(1.665)	1,000
20	XHP-20	47.5(1.870)	50.7(1.996)	52.3(2.059)	500

Material
Nylon 6, UL94V-0, natural (white)

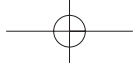

XH CONNECTOR

Through-hole type shrouded header

The shrouded headers are interchangeable with those of the NR, NRD and BR insulation displacement connectors, and JQ board-to-board connectors.

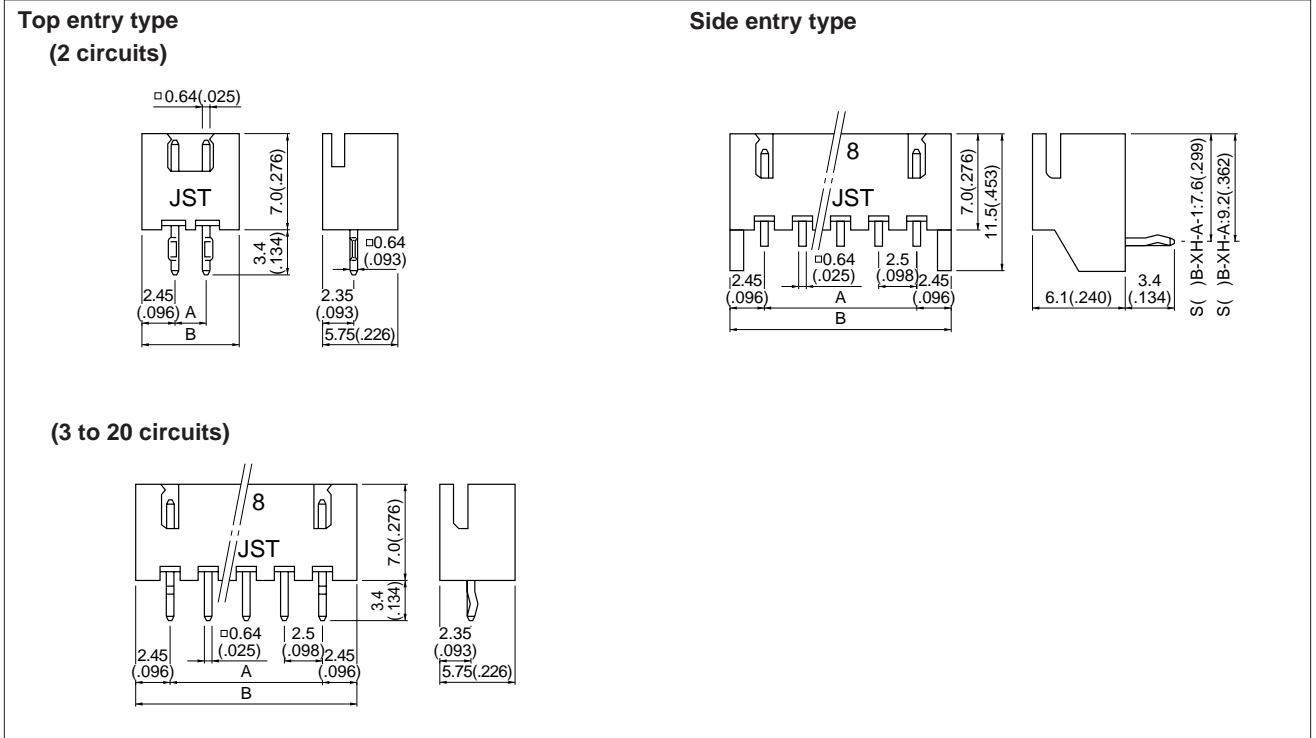

Circuits	Model No.		Dimensions mm(in.)		Q'ty / box		
	Top entry type	Side entry type	A	B	Top entry type	Side entry type	
2	B 2B-XH-A	—	S 2B-XH-A	2.5(.098)	7.4(.291)	1,000	1,000
3	B 3B-XH-A	S 3B-XH-A-1	S 3B-XH-A	5.0(.197)	9.9(.390)	1,000	1,000
4	B 4B-XH-A	S 4B-XH-A-1	S 4B-XH-A	7.5(.295)	12.4(.488)	500	500
5	B 5B-XH-A	S 5B-XH-A-1	S 5B-XH-A	10.0(.394)	14.9(.587)	500	500
6	B 6B-XH-A	S 6B-XH-A-1	S 6B-XH-A	12.5(.492)	17.4(.685)	500	500
7	B 7B-XH-A	S 7B-XH-A-1	S 7B-XH-A	15.0(.591)	19.9(.783)	500	250
8	B 8B-XH-A	S 8B-XH-A-1	S 8B-XH-A	17.5(.689)	22.4(.882)	500	250
9	B 9B-XH-A	S 9B-XH-A-1	S 9B-XH-A	20.0(.787)	24.9(.980)	500	250
10	B10B-XH-A	S10B-XH-A-1	S10B-XH-A	22.5(.886)	27.4(1.079)	250	250
11	B11B-XH-A	S11B-XH-A-1	S11B-XH-A	25.0(.984)	29.9(1.177)	250	250
12	B12B-XH-A	S12B-XH-A-1	S12B-XH-A	27.5(1.083)	32.4(1.276)	250	200
13	B13B-XH-A	S13B-XH-A-1	S13B-XH-A	30.0(1.181)	34.9(1.374)	250	200
14	B14B-XH-A	S14B-XH-A-1	S14B-XH-A	32.5(1.280)	37.4(1.472)	250	200
15	B15B-XH-A	S15B-XH-A-1	S15B-XH-A	35.0(1.378)	39.9(1.571)	250	100
16	B16B-XH-A	—	S16B-XH-A	37.5(1.476)	42.4(1.669)	200	100
20	B20B-XH-A	—	—	47.5(1.870)	52.4(2.063)	100	—

Material and Finish

Post: Brass copper-undercoated, tin/lead-plated
 Wafer: Nylon 66, UL94V-0, natural (white)

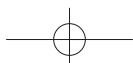

Through-hole type shrouded header

• Top entry type of glass-filled nylon

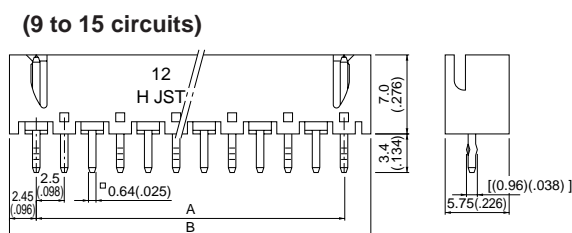
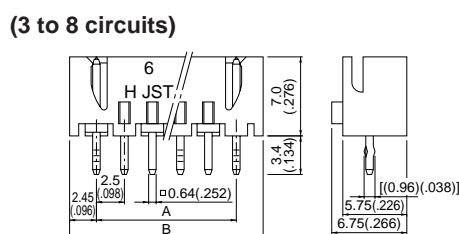
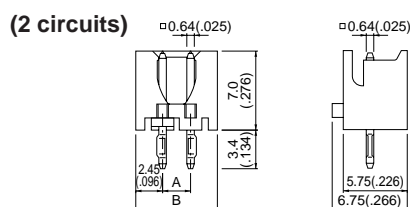

Circuits	Model No.	Dimensions mm(in.)		Q'ty/box
		A	B	
2	B 2B-XH-2	2.5(.098)	7.4(.291)	1,000
3	B 3B-XH-2	5.0(.196)	9.9(.390)	1,000
4	B 4B-XH-2	7.5(.295)	12.4(.488)	500
5	B 5B-XH-2	10.0(.394)	14.9(.587)	500
6	B 6B-XH-2	12.5(.492)	17.4(.685)	500
7	B 7B-XH-2	15.0(.591)	19.9(.783)	500
8	B 8B-XH-2	17.5(.689)	22.4(.882)	250
9	B 9B-XH-2	20.0(.787)	24.9(.980)	250
10	B10B-XH-2	22.5(.888)	27.4(1.079)	250
11	B11B-XH-2	25.0(.984)	29.9(1.177)	250
12	B12B-XH-2	27.5(1.083)	32.4(1.276)	250
13	B13B-XH-2	30.0(1.181)	34.9(1.374)	250
14	B14B-XH-2	32.5(1.280)	37.4(1.472)	250
15	B15B-XH-2	35.0(1.378)	39.9(1.571)	250

Material and Finish

Post: Brass, copper-undercoated, tin/lead-plated

Wafer: Glass-filled nylon 66, UL94V-0, natural (ivory)

XH CONNECTOR

Through-hole type shrouded header

Top entry type with a boss

(1 circuit)

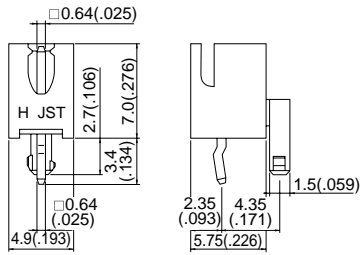

(2 circuits)

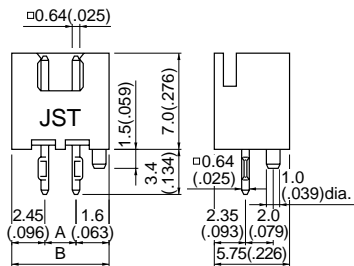

(3 to 6 circuits)

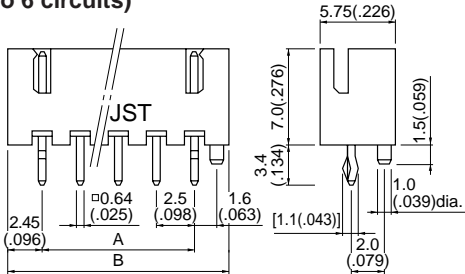

Circuits	Model No.	Dimensions mm.(in)		Q'ty / box
		A	B	
1	B1B-XH-AM	—	—	1,000
2	B2B-XH-AM	2.5(.98)	7.4(.291)	1,000
3	B3B-XH-AM	5.0(.197)	9.9(.390)	1,000
4	B4B-XH-AM	7.5(.295)	12.4(.488)	500
5	B5B-XH-AM	10.0(.394)	14.9(.587)	500
6	B6B-XH-AM	12.5(.492)	17.4(.685)	500

Material and Finish

Post: Brass copper-undercoated, tin/lead-plated
 Wafer: Nylon 66, UL94V-0, natural (white)

Note: B1B-XH-AM is not UL/CSA/TUV approved.

XH CONNECTOR

Through-hole type shrouded header on radial-tape

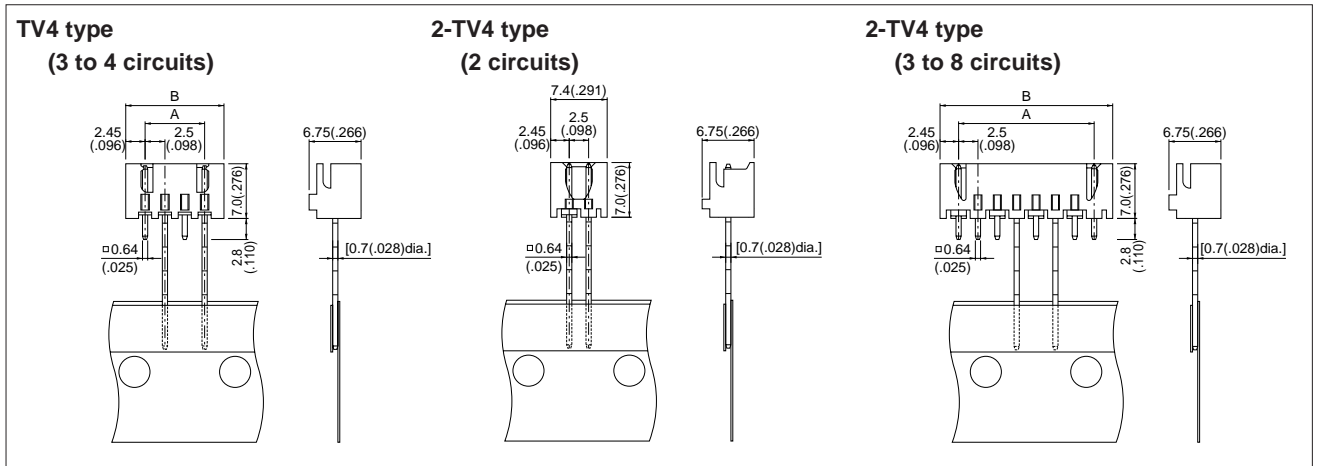

Circuits	Model No.		Dimensions mm(in.)		Q'ty/box
	A	B	A	B	
2	—	B2B-XH-2-TV4	—	—	1,000
3	B3B-XH-TV4	B3B-XH-2-TV4	5.0(.197)	9.9(.390)	1,000
4	B4B-XH-TV4	B4B-XH-2-TV4	7.5(.295)	12.4(.488)	500
5	—	B5B-XH-2-TV4	10.0(.394)	14.9(.587)	500
6	—	B6B-XH-2-TV4	12.5(.492)	17.4(.685)	500
7	—	B7B-XH-2-TV4	15.0(.591)	19.9(.783)	500
8	—	B8B-XH-2-TV4	17.5(.689)	22.4(.882)	500

Material and Finish

Post: Copper alloy, copper-undercoated, tin/lead-plated
 Wafer: TV4 type/ Nylon 66, UL94V-0
 2-TV4 type/ Glass-filled nylon 66, UL94V-0

Taping specification of through-hole type shrouded header

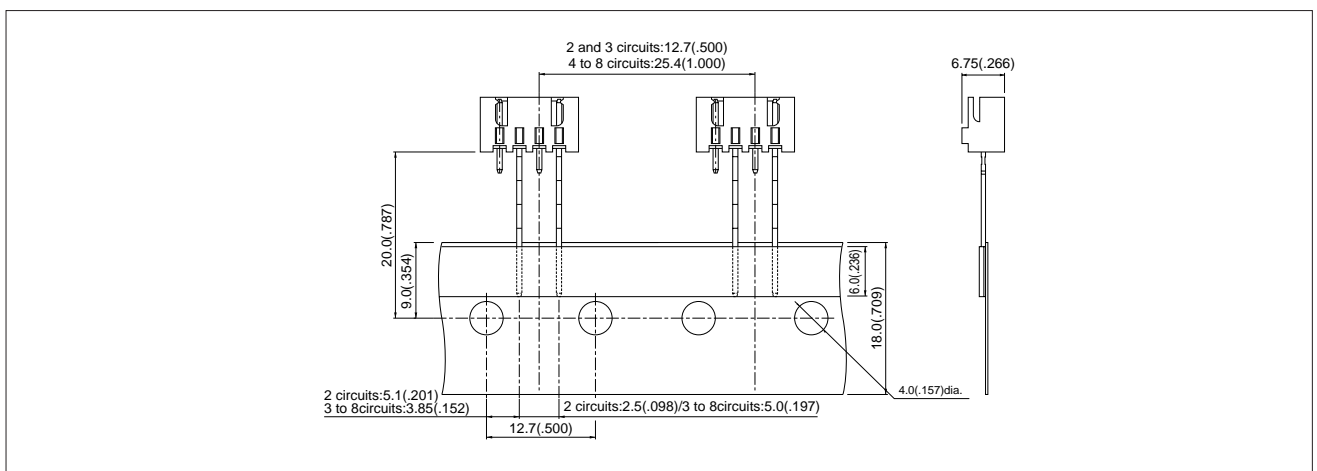

Note : Conforms to JIS C 0805.

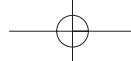

XH CONNECTOR

Packaging specifications of through-hole type shrouded header

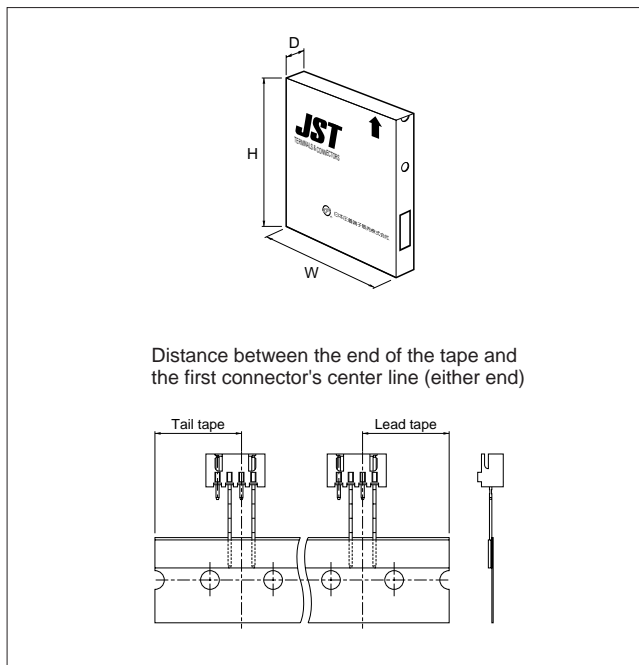

Package type	Flat pack (zig zag folded)
Distance between folds	24 indexing holes perfold (304.8mm/12")
Box size	(316x45x330mm)12.4"(W)x1.8"(D)x13.0"(H)
Distance between the end of the tape and the first connector's center line (either end)	19.05mm(.750")

Products of different packaging specifications are also available. Contact JST for details.

Through-hole type PC board layout (viewed from soldering side) and Assembly layout

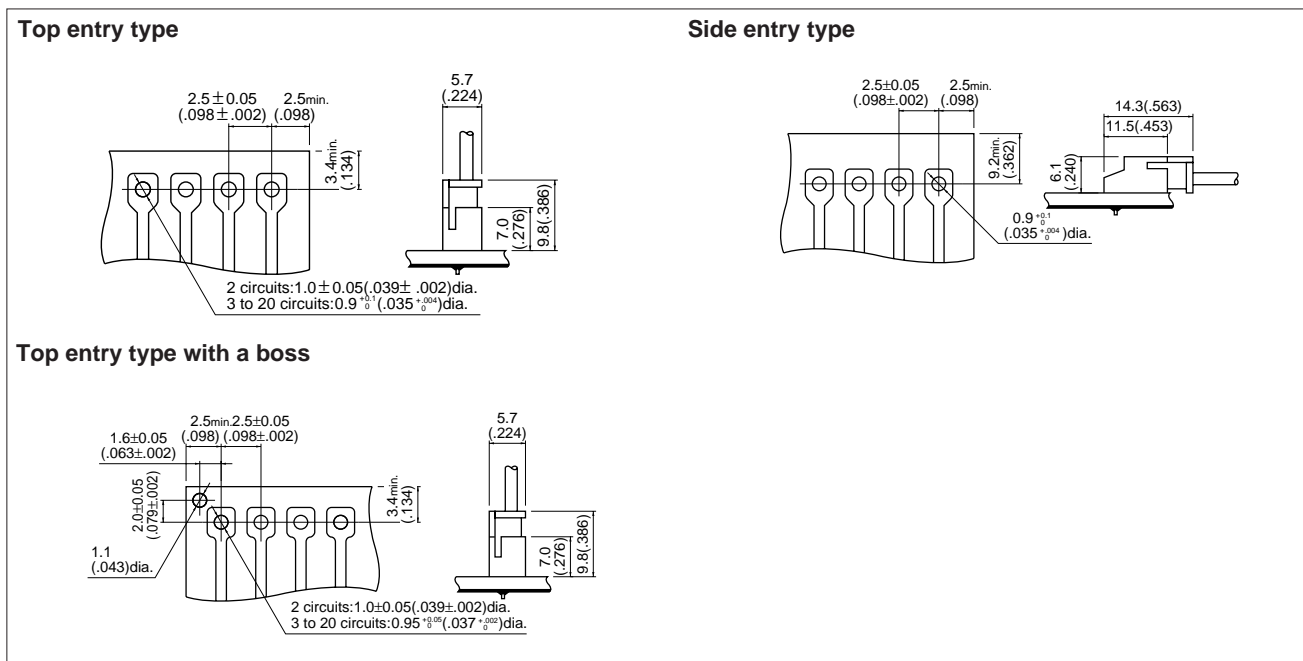

Note:

1. Tolerances are non-cumulative: ±0.05mm (±.002") for all centers.
2. Hole dimensions differ according to the kind of PC board and piercing method. If printed circuit boards made of hard material such as FR-4 are used, the hole dimensions should be larger. The dimensions above should serve as a guideline. Contact JST for details.

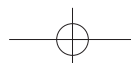

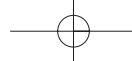

XH CONNECTOR

SMT type shrouded header

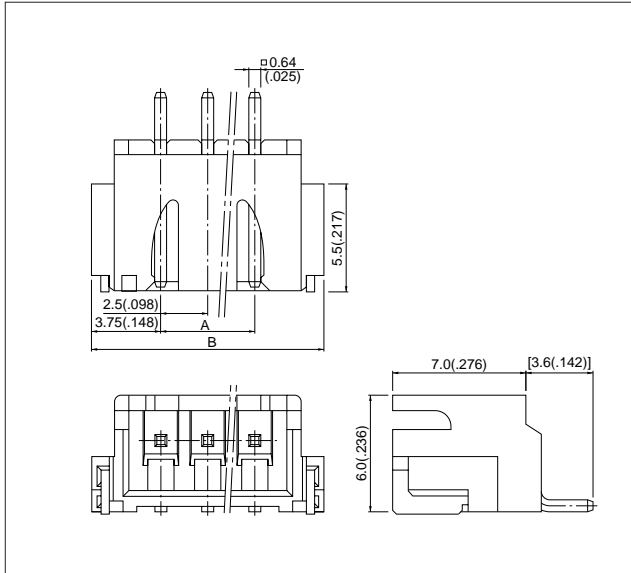

Circuits	Model No.	Dimensions mm.(in)		Q'ty / reel
		A	B	
3	S3B-XH-SM3-TB	5.0(.197)	12.5(.492)	500
4	S4B-XH-SM3-TB	7.5(.295)	15.0(.591)	500
6	S6B-XH-SM3-TB	12.5(.492)	20.0(.787)	500

Material and Finish

Pin: Copper alloy, Copper-undercoated, tin/lead plated
 Wafer: Glass-filled nylon 46, UL94V-0, natural (white)
 Solder tab: Brass, Copper-undercoated, tin/lead plated

Note: The products listed above are supplied on embossed-tape.

Taping specifications of SMT type shrouded headers

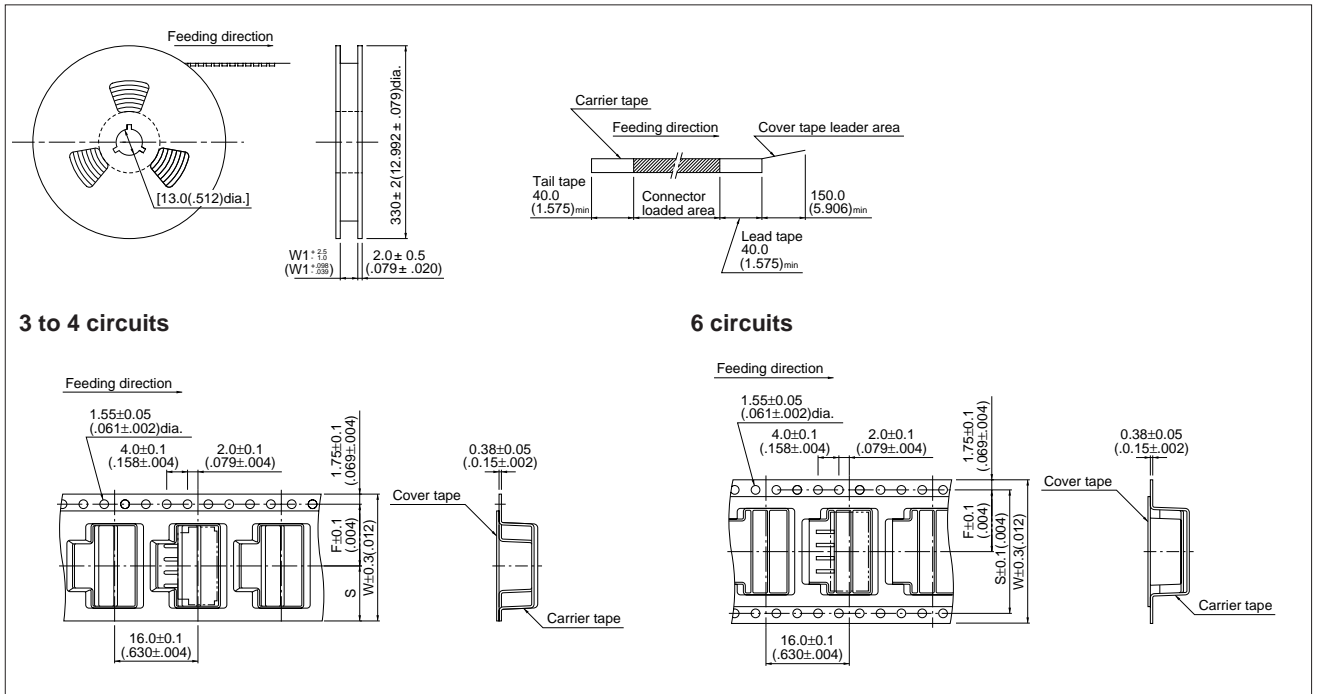

Circuits	Taping dimensions mm.(in.)			Reel dimensions mm.(in.)	Q'ty / reel
	F	S	W	W1	
3 to 4	11.5(.453)	[10.75(.423)]	24.0(.945)	25.5(1.004)	500
6	14.2(.559)	28.4 (1.118)	32.0(1.260)	33.5(1.319)	500

Note: Specifications conform to JIS C 0806. The tape width, connector recess dimensions, etc. are determined by the number of circuits and external shape of the connector to be loaded.

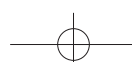

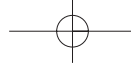

XH CONNECTOR

SMT type PC board layout (viewed from component side)

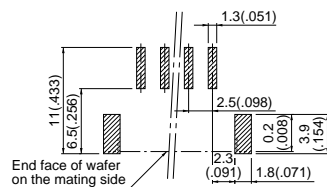

Note:

1. Tolerances are non-cumulative: $\pm 0.05\text{mm} (\pm .002")$ for all centers.
2. The dimensions above should serve as a guideline. Contact JST for details.

